

Surface Tension, Coexistence Curve, and Vapor Pressure of Binary Liquid–Gas Mixtures¹

V. T. Do² and J. Straub³

The objective of this paper is to present measurements of the vapor pressure, capillary coefficient, and refractive index of four binary mixtures, CO₂–SF₆, R14–SF₆, SF₆–R13B1, and SF₆–R22, at liquid–vapor equilibrium at different average concentrations. The measuring temperature range covered the entire liquid–vapor region from the triple line up to the critical point. The capillary coefficient was determined by means of the capillary rise method; the refractive index, by measuring the angle of refraction of a light beam passing through a prism and the sample. In order to obtain the liquid–vapor densities of pure substances the Lorentz–Lorenz relation can be used. However, in applying this relation to calculate the liquid–vapor densities of a mixture, one may need the concentrations of both the liquid and the vapor phase, which are, for the most part, quite different from the average concentration of the mixture. Calculating the concentrations of both fluid phases with the aid of an equation of state and comparing with measurements, we could show that the molar refraction coefficient of the mixtures can be simply determined from the average concentration and the molar refraction coefficients of their pure components. The surface tension of the mixtures could then be calculated from the measured capillary coefficient and the refractive index with the aid of the Lorentz–Lorenz relation.

KEY WORDS: capillary coefficient; coexistence curve; Lorentz–Lorenz relation; mixtures; refractive index; surface tension.

1. INTRODUCTION

In physical systems in which two phases occur, as in boiling, condensation, two-phase flows, etc., the surface tension is necessary for the understanding

¹ Paper presented at the Ninth Symposium on Thermophysical Properties, June 24–27, 1985, Boulder, Colorado, U.S.A.

² L. & C. Steinmüller, Fabrikstr. 1, 5270 Gummersbach, Federal Republic of Germany.

³ Lehrstuhl A für Thermodynamik, Technische Universität München, Arcisstrasse 21, 8000 München 2, Federal Republic of Germany.

Table I. Some Characteristic Data of the Pure Gases

Gas	Molar weight (g · mol ⁻¹)	Dipole moment (D)	T_c (°C)	p_c (bar)	Mol. refr. coefficient (cm ³ · mol ⁻¹)
SF ₆ (R846)	146.05	0	45.52	37.66	11.3437
CO ₂	44.01	0	31.04	73.81	6.6077
CF ₄ (R14)	88.01	0	-46.63	37.55	7.2001
CBrF ₃ (R13B1)	148.91	0.65	67.04	39.86	14.5217
CHClF ₂ (R22)	86.47	1.42	96.12	49.37	11.8308

of two-phase phenomena and for the practical calculation of such problems. For binary mixtures a wide gap of data exists in an extended temperature region, so that relations can be checked only over small temperature and concentration ranges. Therefore, we start with measurements of surface tension for binary mixtures covering the entire liquid-vapor region from the triple line up to the critical point.

For a systematic investigation, sulfur hexafluoride (SF₆) was chosen as one component of binary mixtures. SF₆ is spherical and nonpolar and has often been investigated, so that we can obtain all necessary data from the literature. The other components are CO₂, CF₄ (R14), CBrF₃ (R13B1), and CHClF₂ (R22). Some characteristic data of these gases are compiled in Table I. The molar weights of CO₂, R14, and R13B1 relate to each other as 1:2:3 so that their influence on the surface tension can be studied. Besides, it is of interest with regard to the results of this investigation that the chosen gases have different molecular structures and polar properties, which have a direct effect on the surface tension.

The surface tension is determined by means of the capillary rise method, where first, the capillary coefficient is measured and, then, together with the coexistence densities, the surface tension is determined. Therefore, the refractive index of the liquid and vapor phase are simultaneously measured to get the density values with the aid of the Lorentz-Lorenz relation. The vapor pressure of the mixtures is additionally measured at the same temperatures, so we receive a coherent set of data in the two-phase region of binary mixtures.

2. EXPERIMENTAL METHOD AND APPARATUS

The capillary rise method applied in this work was proposed by Sugden [1]. The principle is sketched in Fig. 1. Four capillaries with the internal diameters, 0.122, 0.195, 0.389, and 0.778 mm, were used to measure

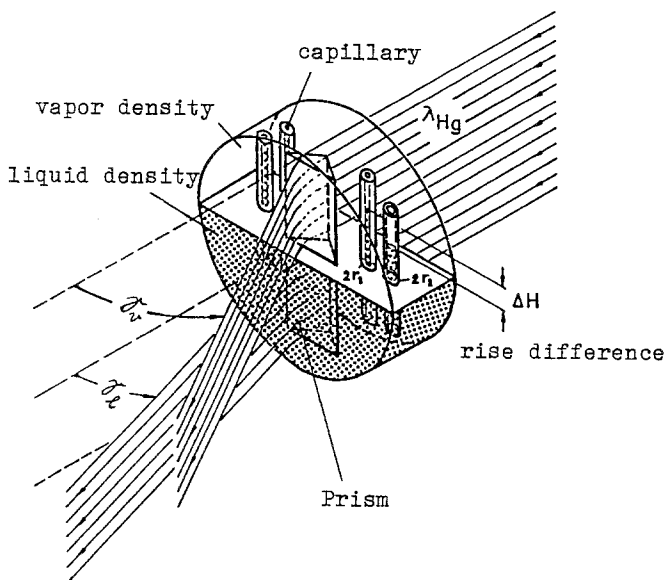

Fig. 1. Schematic view of the experimental method.

the capillary coefficient a^2 over the whole temperature range from the triple line up to the critical point. The vertical distance ΔH between the menisci in two capillaries is measured by means of a cathetometer. Assuming the contact angle between fluid and glass to be zero, the capillary coefficient a^2 can then be iteratively calculated from ΔH by Sugden's method. The principal error is due to the subjective localization of the meniscus in a capillary tube: $\Delta(\Delta H) \leq 0.01$ mm. The possible maximum error of a^2 can be summarized in Eq. (1):

$$\Delta a^2 = 4.8 \times 10^{-3} a^2 + 1.2 \times 10^{-2} \text{ mm}^2 \quad (1)$$

The first term refers to the uncertainty in the capillary radii and the second to $\Delta(\Delta H)$, which is the most important term at the temperature region near the critical point, because the error in the capillary height $\Delta(\Delta H)$ remains constant with temperature.

The measurements of the refractive index were carried out at a wavelength of $\lambda = 546$ nm with a mercury vapor lamp. The light passes through an adjustable slit on a collimator and penetrates the sample as a parallel beam. An autocollimating telescope, mounted on an optical rotary table, was used to position the prism and to observe the angle of refraction (γ_1, γ_v). The precision of angle measurement was higher than ± 2 in., corresponding to an uncertainty of the refractive index $\Delta n/n < 10^{-4}$. The overall uncertainty is estimated to be within $\Delta n/n < 3 \times 10^{-4}$.

The temperature has been measured with a 100- Ω platinum resistance thermometer calibrated by means of a standard thermometer, which was previously calibrated at the Physikalisch-Technische Bundesanstalt, Braunschweig. The accuracy of the temperature measurement is 0.01 K for temperatures near room temperature and 0.05 K for very low temperatures; the relative accuracy is about 1 mK.

The most essential elements of the apparatus (Fig. 2) are (a) a stainless-steel pressure vessel with windows of fused quartz and four capillaries and a prism in the center, the internal diameter being 48 mm; (b) a vacuum housing of aluminum; (c) the pressure vessel, which is cooled by a controlled stream of liquid nitrogen flowing through bifilar channels at low temperatures and is heated electrically at high temperatures; and (d) the sealing elements between the vessel and the glass windows, made of heat treated steel. Details of the apparatus are described in Refs. 2 and 3.

The vapor pressure is measured with a diaphragm-measuring instrument, which is directly connected with the vessel on one side and with a nitrogen storage bottle on the other. At the balanced position of the diaphragm the vapor pressure in the vessel is equal to the nitrogen pressure and is measured either by a mercury U tube at low pressure ($p \leq 2$ bar) or by means of a pressure gauge at high pressure. The diaphragm-measuring instrument is located at the same height as the sample vessel in a thermostat, which is kept at a constant temperature higher than the critical. The average accuracy of this pressure measurement is about ± 6 mbar.

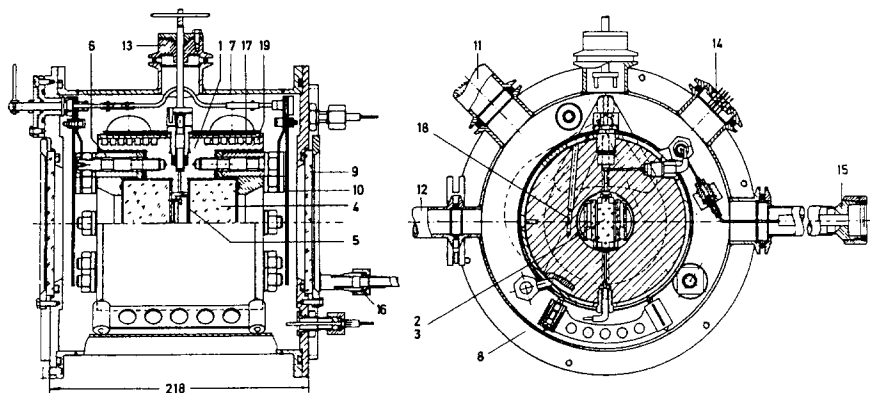

Fig. 2. Apparatus. (1) Pressure vessel, (2 and 3) capillaries and prism, (4) windows, (5) sealing, (6) compensation of thermal expansion, (7) aluminium housing, (8) prop, (9) windows, (10) radiation shield, (12) handling of valve, (14) electrical contacts, (15) LN₂ inlet, (16) N₂ outlet, (17) electrical heating, (18) thermometer well, (19) bifilar canals.

The gas mixture to be investigated, which was produced and analyzed by Linde Gas Company, was distilled from the storage bottle into the sample vessel up to half-height. The measuring temperature range covered the whole liquid-vapor region from the triple line up to the critical point. After the measurements the sample was gasified and the preservation of the average concentration was verified with a gas chromatograph.

3. EXPERIMENTAL RESULTS

One component of all four binary mixtures is SF₆ mixed with the pure substances compiled in Tables I and II. The measurements were carried out at liquid-vapor equilibrium at different average concentrations of the mixtures. Figures 3, 4, and 5 show, as a function of the temperature, the vapor pressure, the capillary coefficient, and the refractive index of the mixture CO₂-SF₆ at three average molar concentrations, 15, 49.3, and 84.45%, referring to CO₂. For comparison, the data on the pure substances taken from the literature [3, 4] are also included in these figures. The insets show the functional dependence of the measured properties on the concentrations of the mixture as isotherms.

Table II: Critical Parameters of the One-Term Power Law

Gas	T_c (K)	a_0^2 (mm ²)	φ	for $T/T_c \geq 0.9$			
				B	β	δ_0 (mN · m ⁻¹)	μ
SF ₆	318.67	3.931	0.943	0.223	0.343	53.98	1.286
CO ₂	304.19	9.43	0.932	0.274	0.348	84.50	1.280
R14	226.52	4.064	0.946	0.191	0.341	46.506	1.287
R13B1	340.19	3.879	0.938	0.281	0.341	54.05	1.279
R22	369.27	6.859	0.937	0.283	0.346	69.03	1.283
15% CO ₂ -SF ₆	314.023	4.038	0.961	0.219	0.343	53.319	1.304
49.3% CO ₂ -SF ₆	301.946	4.989	0.987	0.253	0.377	65.780	1.364
84.45% CO ₂ -SF ₆	297.235	6.505	0.915	0.253	0.332	65.797	1.247
49.7% R14-SF ₆	279.769	3.186	0.914	0.201	0.340	39.642	1.254
24.8% SF ₆ -R13B1	332.254	3.836	0.947	0.267	0.343	54.197	1.290
50.2% SF ₆ -R13B1	325.353	3.783	0.939	0.244	0.331	51.640	1.270
75% SF ₆ -R13B1	320.791	3.783	0.928	0.233	0.336	52.261	1.264
25% SF ₆ -R22	350.882	4.884	0.940	0.264	0.367	54.735	1.307
50.5% SF ₆ -R22	333.187	4.424	0.941	0.247	0.350	53.911	1.291
75.2% SF ₆ -R22	321.873	4.220	0.941	0.232	0.343	54.972	1.284

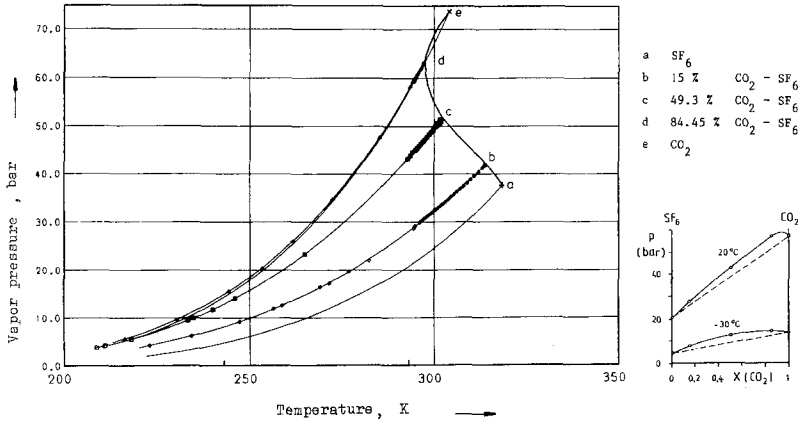

Fig. 3. Vapor pressure of the mixture CO₂-SF₆.

The following functions, with $\tau = 1 - T/T_c$ as the dimensionless temperature, are used to fit the measured data from the triple line up to the critical point (index c).

For the vapor pressure p ,

$$\ln p/p_c = T_c/T(A_1\tau + A_2\tau^{1.5} + A_3\tau^3 + A_4\tau^4 + A_5\tau^5) \quad (2)$$

For the capillary coefficient a^2 ,

$$a^2 = a_0^2\tau^\varphi \quad (3)$$

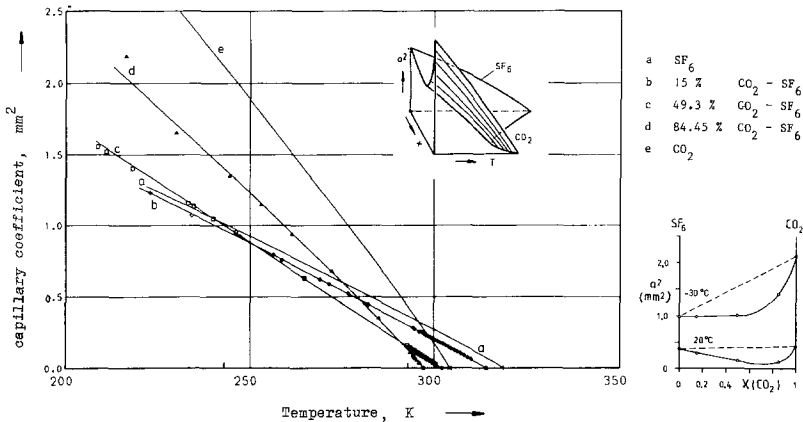

Fig. 4. Capillary coefficient of the mixture CO₂-SF₆.

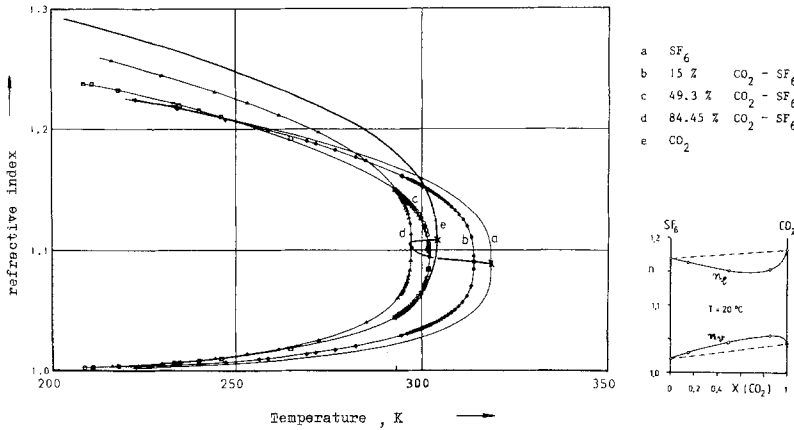

Fig. 5. Refractive index of the mixture CO₂-SF₆.

For the refractive index $n_{1,v}$ of the liquid and vapor phase,

$$(n_1 + n_v) = n_c + C\tau$$

$$n_{1,v} = n_c + \sum_{i=1}^5 C_{i,v} \tau^{i/3} \tag{4}$$

All parameters of these equations as well as the experimental results of the mixtures R14-SF₆, SF₆-R13B1, and SF₆-R22 are given in Ref. 2.

4. SURFACE TENSION OF MIXTURES

Based on the capillary rise method the surface tension δ is defined in the following equation:

$$\delta = a^2 g (\rho_l - \rho_v) / 2 \tag{5}$$

where a^2 is the measured capillary coefficient and g the acceleration due to gravity. The contact angle of the liquid with glass is assumed to be zero, i.e., the liquid wets the glass capillary.

In order to obtain the liquid and vapor densities $\rho_{1,v}$ by measuring the refractive index n , the Lorentz-Lorenz relation can be used:

$$\frac{n^2 - 1}{n^2 + 2} \frac{M}{\rho} = L \tag{6}$$

where M is the molar weight. It is known that for pure substances the molar refraction coefficient L alters only insignificantly in the whole

liquid-vapor region [3, 4] and can practically be considered as constant. For a mixture, however, the molar refraction coefficient depends on the mixture concentration; for this different mixing rules are proposed in the literature. Heller [5] investigated the mixture propyl alcohol + ethyl bromide, for which the partial volumes are additive, as well as the mixture bromoform + acetone, for which the mix-volume extends. He found that the linear mixing rule for the molar refraction coefficient is valid for non-colloidal liquid mixtures.

Applying this mixing rule to both the molar weight and the molar refraction coefficient, we get,

for the liquid phase at concentration x ,

$$M_l = \sum_i x_i M_i; \quad L_l = \sum_i x_i L_i \quad (7)$$

and, for the vapor phase at concentration y ,

$$M_v = \sum_i y_i M_i; \quad L_v = \sum_i y_i L_i \quad (8)$$

Consequently, the density difference between the liquid and the vapor phase results in

$$\rho_l - \rho_v = \left[\frac{n^2 - 1}{n^2 + 2} \frac{M}{L} \right]_l - \left[\frac{n^2 - 1}{n^2 + 2} \frac{M}{L} \right]_v = \Delta\rho(x, y) \quad (9)$$

The next question is how to define the concentrations x , y of the two coexisting phases. Aside from the equality of temperature and pressure, the liquid-vapor equilibrium demands—regarding the mass transfer—the equality of fugacity. This condition describes a relation among T , p , x , and y . According to the Gibbs's phase doctrine, two of these properties are independent variables; the other two can then be evaluated. With the aid of the equation of fugacity [6] and an equation of state (in this work the Lee-Kesler-Plöcker (LKP) equation [7] is chosen), the concentrations x and y were calculated with knowledge of the temperature and pressure.

The T , x diagram of the mixture CO_2 - SF_6 is sketched in Fig. 6. In curves 1 and 3, at average concentrations of 32 and 67.9% CO_2 , the measured data of Ref. 8 correspond very well with the calculated concentrations x , y . Curves 2 and 4 show the calculated liquid-vapor concentrations of our measurements at a concentration of 49.3 and 84.45% CO_2 . For the mixture with 15% CO_2 no convenient result from the calculation could be obtained. At high temperatures ($T \geq 0.94 T_c$) all the curves in Fig. 6 are extrapolated because the chosen LKP equation of state becomes inaccurate.

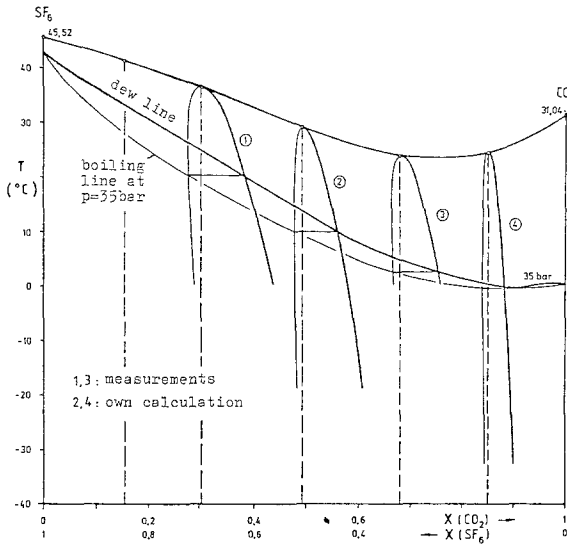

Fig. 6. T, x diagram of the mixture $\text{CO}_2\text{-SF}_6$.

On the assumptions that the average concentration is $x_m = x = y$ and the refractive coefficient is $L = L_l = L_v$, one gets from Eq. (9)

$$\rho_l - \rho_v = \left[\left(\frac{n^2 - 1}{n^2 + 2} \right)_l - \left(\frac{n^2 - 1}{n^2 + 2} \right)_v \right] \frac{M}{L} = \Delta\rho(x_m) \quad (10)$$

With all obtainable results of the LKP equation of state, the percentage deviation between relation (9) and relation (10) was calculated and is sketched in Fig. 7. The small deviation ($\leq 2\%$) is due to the following reasons.

- (a) With decreasing temperature the second term of the two equations tends to zero, because the refractive index of vapor becomes 1. The vapor density can be neglected and the liquid concentration x is equal to the average concentration x_m so that the deviation disappears.
- (b) The liquid and the vapor phases become more similar near the critical point. At the critical temperature both phases have the same concentration, x_m . The deviation in Fig. 7 at higher temperatures is due to the inaccuracy of the equation of state.
- (c) The liquid and vapor concentrations are implicitly considered by the local refractive indices measured.

Therefore the use of Eq. (10) seems to be justified.

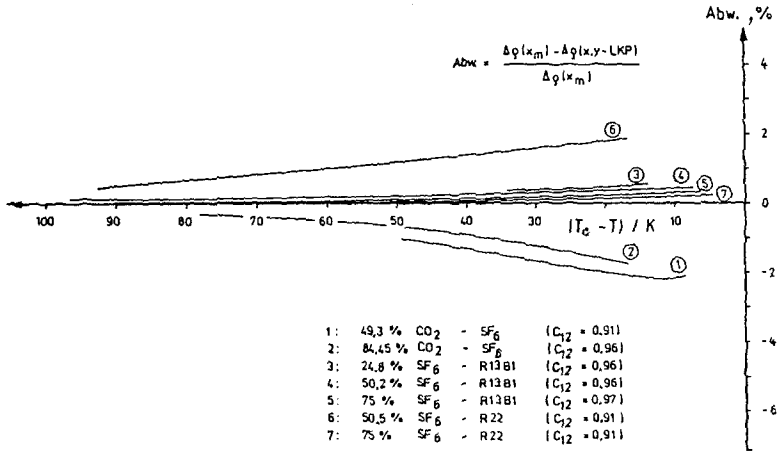

Fig. 7. Comparison between the density differences.

Figure 8 shows the measured surface tension of the mixture CO₂-SF₆. To calculate the temperature dependence of the surface tension (curves plotted in Fig. 8), the one-term power law was first used for the density difference:

$$\rho_l - \rho_v = BM\tau^\beta/L \tag{11}$$

The parameters B and β were defined by fitting the measured refractive index in Eq. (10) by means of the least-error squares.

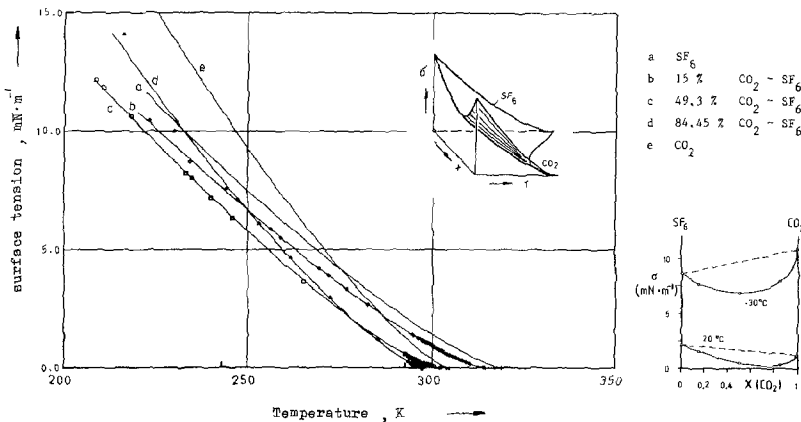

Fig. 8. Surface tension of the mixture CO₂-SF₆.

Together with Eqs. (3) and (5) we get the following parameters δ_0 and μ of the one-term power law for the surface tension:

$$\delta = \delta_0 \tau^\mu \quad (12)$$

with

$$\delta_0 = a_0^2 g B M / (2L)$$

$$\mu = \varphi + \beta$$

The total uncertainty for the surface tension is estimated at 1 or, maximum 2%.

In Table II the calculated parameters of the capillary coefficient, the density difference, and the surface tension of the four investigated mixtures are compiled. In comparison with the mixtures, the data of the pure components are also given in Table II.

With our measurements we get the following nonweighted mean value of the critical exponents for the mixtures, which correspond with the value for the pure components [3, 4]:

$$\varphi = 0.941 \pm 0.014$$

$$\beta = 0.346 \pm 0.011$$

$$\mu = 1.287 \pm 0.025$$

ACKNOWLEDGMENT

This research was supported by the Deutsche Forschungsgemeinschaft, which we would gratefully like to acknowledge.

REFERENCES

1. S. Sugden, *J. Chem. Soc.* **119**:1483 (1921).
2. V. T. Do, Dr. Ing. thesis (Techn. Univ. München, München, FRG, 1982).
3. W. Rathjen and J. Straub, Surface tension and refractive index of six refrigerants from triple point up to the critical point, Proceedings of the 7th Symposium on Thermophysical Properties (1977), pp. 839-850.
4. W. Rathjen and J. Straub, *Wärme- Stoffübertragung* **14**:59 (1980).
5. W. Heller, *J. Phys. Chem.* **69**(4):1123 (1965).
6. J. A. Beattie, *Chem. Rev.* **44**:141 (1949).
7. U. J. Plöcker, H. Knapp, and J. M. Prausnitz, *Ind. Eng. Chem. Process Des. Dev.* **17**(3):324 (1978).
8. E. Reile, Dr. Ing. thesis (Techn. Univ. München, München, FRG, 1981).